

Auchan shopping mall, Budapest

Waterproofing systems from Sika keep roofing reliably tight. A major product for this purpose in Sikaplan®-15 G.

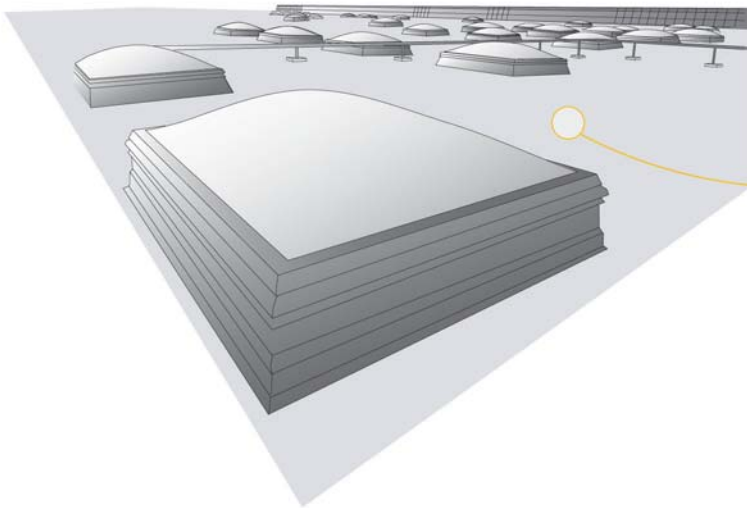
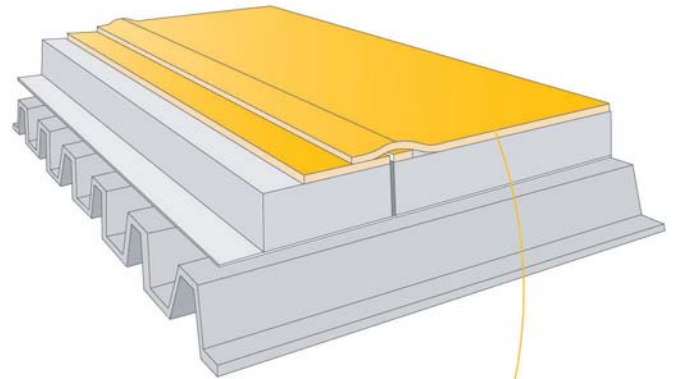

Cost-effective performance: A boom is not merely characterized by rising stock prices, but also thrives on growing consumption and on the strength of a solid infrastructure. Throughout Eastern Europe and in particular among the new members of the European Union feverish construction activities are fueling a let's-get-going spirit. Logistics centers, do-it-yourself stores, shopping malls are sprouting out of the earth, yet not without due respect to price and time factors.

On account of its know-how Sika is an ideal partner wherever the entrepreneurial spirit prevails. To seal flat roofs, for instance, Sikaplan®-15 G, a PVC membrane with a polyester weave as reinforcement, has become a product of choice. Installations are quick and cost-effective, the membrane is temperature and vibration resistant and waterproofs reliably. These advantages are exemplified by the Auchan shopping mall, Budapest. In

wintery weather conditions 34 000 square meters of roofing had to be installed rapidly and precisely. Considerable snow and the inhospitable climate generated added time pressures and made the job of sealing a race against the weatherman.

However, it was not happenstance that those responsible for the project put their trust in Sika. Hidrostop Kft. (Pécs, Hungary), a specialist in sealing flat roofs, has not only been working with Sika for some ten years, but together they have some impressive successes to their credit. In 2003 the Hungarian association of sealers and roofers gave its «Roof of the Year» in the «PVC» category award to General Electric Power Systems' production facility in Veresegyháza. The roof required 36 700 square meters of Sikaplan®. Hidrostop installed it; the waterproofing system was Sika's.

